

---

**HEDMAN®**

---

THE HEDMAN COMPANY • 1158 West Armitage • Chicago, Illinois 60614 • (312) 871-6500

---

***OPERATING INSTRUCTIONS  
HE-1500  
CHECK AUDIT SYSTEM***

---

**HEDMAN®**

---

THE HEDMAN COMPANY • 1158 West Armitage • Chicago, Illinois 60614 • (312) 871-6500

---

## NOTES

### **INFORMATION**

This material is not to be reproduced by any means or disclosed in any way without prior written approval by **THE HEDMAN COMPANY**.

### **DISCLAIMER**

This material is subject to change without notice and should not be construed as a commitment by **THE HEDMAN COMPANY**. Neither expressed nor implied warranty is made regarding the procedures herein, their merchantability, or fitness for any specific application.

These procedures are provided solely on an "as-is" basis, and the customer agrees to assume any cost arising from use or misuse of the material, including all correction and damages, consequential or incidental.

**ALL RIGHTS RESERVED**  
by  
**THE HEDMAN COMPANY**

# OPERATOR TROUBLESHOOTING GUIDE

SYMPTOM	POSSIBLE CAUSE	CORRECTIVE ACTION
Document does not print.	Print head is not in home position.	Turn unit OFF and then ON to reset printer.
Display does not change when making entries.	Attempting to make entries in improper sequence.	Refer to Operator or Programmer reference manual.
Information printing at incorrect locations on the document.	Using wrong account key when processing transaction or not properly aligning when inserting document.	Verify proper account key is being used. If problem persists, have your manager verify print locations in "Print Location Mode".
"Access Denied" appears whenever operator enters password.	Incorrect password entry or set up.	Have your manager verify password in "Password Setup Mode".
"Exceeded Limit" appears when entering amounts.	Operator accessing wrong account key or amount of entry exceeds "Account Limit".	Have your manager verify proper account key is being used, and the Account Limit in the "Account Options Mode"
Display fails to illuminate.	No power.	Verify power cord is plugged into wall outlet.
Poor print quality.	Worn ribbon.	Replace ribbon.
Paper jams.	Improper ribbon installation, paper path obstructed or improperly fed document.	Check ribbon installation, attempt to clear paper path by depressing "SCROLL" key or turn power OFF and carefully removing document.
Document does not fully eject.	Form length set incorrectly.	Have your manager verify form length setting in "Print Location Mode"
Document is smeared.	Paper may be creased or paper weight may be too heavy.	Use only new, clean paper stock.
Unit prints on backside or upside down.	Document inserted improperly.	Refer to Operator Manual.
Document feed problem.	Paper may be creased or paper weight may be too heavy.	Use only new, clean paper stock.

## KEYS DEFINED:

"I" (ON)/"O" (OFF) key lock. Turn to "I" to turn the HE-1500 ON. The unit may be locked by removing the key in the OFF position.

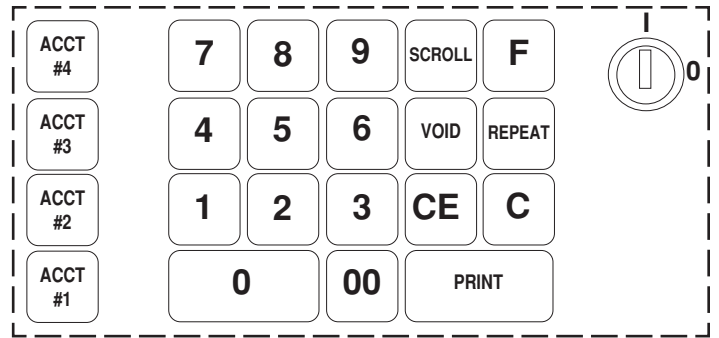

"F" key is used to access reports and for programming.

**SCROLL (Date & Time)** key is for form feed and also to set date and time. Setting date and time are only accessible when memory has been cleared.

**ACCT** keys each represent a different account or document.

"0" thru "9" and "00" numeric keys are used to enter numeric values.

**PRINT** key is used to print documents or to enter data.

"C" key is used to clear an entire operation and return to the Home Menu.

"CE" key is used to clear numeric entries.

**REPEAT** key is used to repeat a previous transaction.

**VOID** key is used to void a transaction. Void key can be deactivated by programmer.

**NOTE:** If the unit prompts for a yes or no (Y/N) answer, Y="1" and N="0"

## PASSWORD:

The HE-1500 can be programmed to require a password before operating the machine. If necessary, enter your password and press **PRINT**. The machine is then ready for transactions.

When password is activated a 5 to 99 second timeout will also be activated. If nothing is entered in the machine for the amount of seconds programmed, the display will return to the home menu.

- KEYSTROKE -

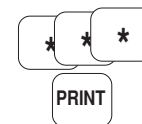

IF PASSWORD IS NOT ACCEPTED

- DISPLAY -

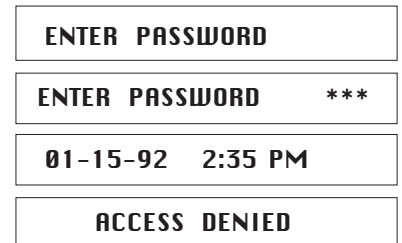

## PRINTING CHECKS:

The HE-1500 can print "cutsheet" checks of up to 9-1/2" wide x 16-1/2" long. Insert check by placing it backwards and upside down into the paper guide (just like a typewriter). Then align the left edge of check with left edge of guide.

When using multi-part forms align the glued or fastened edge with the corresponding edge of the guide. i.e. if the right edge is glued align it with the right edge of the guide.

- KEYSTROKE -	- DISPLAY -
<b>Insert Check</b>	<b>01-15-92 2:35PM</b>
ACCT #1	# 1 0.00 AMT
1 5 0 0 0 0	# 1 1500.00 AMT
PRINT	# 1 1500.00 TL
<b>Remove Check</b>	<b>01-15-92 2:35PM</b>
<b>INSERT DOC-PRESS PRINT</b>	

**NOTE:** If document has not been inserted when "PRINT" is pressed the following prompt will be displayed.

## TRANSACTIONS INVOLVING FEES:

An account can be programmed to allow adding and reporting of fees charged to customers.

- KEYSTROKE -	- DISPLAY -
<b>Insert Check</b>	<b>01-15-92 2:35PM</b>
ACCT #3	# 3 0.00 AMT
4 5 0 0 0 0	# 3 4500.00 AMT
PRINT	# 3 0.00 FEE
5 0	# 3 0.50 FEE
PRINT	# 3 4500.50 TL
<b>Remove Check</b>	<b>01-15-92 2:35PM</b>

## RIBBON REPLACEMENT

**CAUTION: Turn off power.**

- 1) Move the printhead to the center, so that it is in front of the cut-out in the top cover.
- 2) Remove ribbon cartridge from the package.
- 3) Turn the take-up knob to tighten the ribbon. Refer to Figure 2.
- 4) Do not remove the plastic film on the front of the cartridge - it is part of the cartridge.
- 5) Slide the cartridge under the top cover and position it so that its centered over the print head.
- 6) Engage the "slots" at the rear of the cartridge.
- 7) Lower the front of the cartridge over the print head, making sure that the locking tabs on each side of the cartridge are engaged. Refer to Figure 1.
- 8) Press down on the cartridge to make sure that it is fitted correctly and locked into place. Refer to Figure 2.

**NOTE:** You will find that it is easier to replace the ribbon cartridge if you "flex" the top cover (up) while removing and replacing the ribbon cartridge.

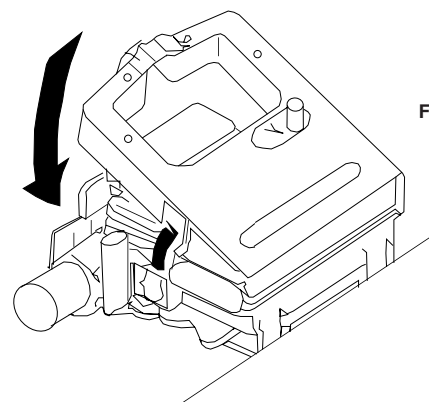

Figure 1

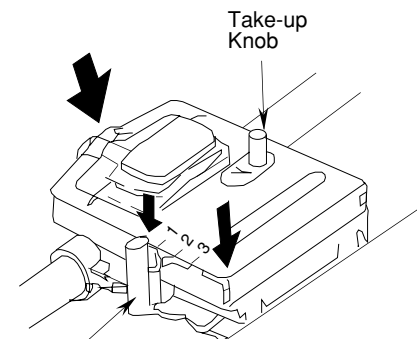

Figure 2

Printhead Gap Lever is factory set at #3. Leave it at this position if multi-part documents are used. If single part documents are used move the lever to position #2 or #1.

## CARE AND MAINTENANCE OF THE HE-1500

The HS-1500 is designed to withstand normal day-to-day operation and operate trouble-free with little care and maintenance.

For optimal operation you must clean the HE-1500 as follows:

- 1) Turn OFF the HE-1500.
- 2) Use soft cloth to carefully remove all dust and dirt.
- 3) If outer case is dirty, clean with a soft, clean cloth dampened with a mild detergent or soap solution. Keep cover in place to prevent solution from getting inside the unit.

### WARNING

DO NOT USE ABRASIVE CLEANERS, ALCOHOLS OR THINNERS TO CLEAN THE HE-1500. THEY CAN DAMAGE THE CASE AND THE ELECTRONIC COMPONENTS.

DO NOT SPRAY DIRECTLY ON OR INSIDE THE HE-1500 WITH CLEANING SOLUTION OR LUBRICANTS; IT COULD CAUSE THE ELECTRONIC COMPONENTS AND THE CASE TO BE DAMAGED.

## CHECK NUMBER SEQUENCE:

An account can be programmed to allow tracking of check numbers. Check numbers will print on reports only and to a maximum of ten digits.

**NOTE:** If both "FEE" and "CHECK #" are activated, "FEE" comes up first.

- KEYSTROKE -	- DISPLAY -
<b>Insert Check</b>	01-15-92 2:35PM
ACCT #2	# 2 0.00 AMT
2 5 0 0 0 0	# 2 2500.00 AMT
PRINT	# 2 CHECK #
1 2 3 4	# 2 1234
PRINT	# 3 2500.00 TL
<b>Remove Check</b>	01-15-92 2:35PM

## REPEATING TRANSACTIONS:

Repeat transactions for the same amount can be completed by simply using the Repeat key. Depressing the Repeat key will recall the immediately previous transaction.

- KEYSTROKE -	- DISPLAY -
<b>Insert Check</b>	01-15-92 2:35PM
REPEAT	# 3 4500.50 R
PRINT	# 3 4500.50 R
<b>Remove Check</b>	01-15-92 2:35PM

**VOIDING TRANSACTIONS:**

A check can be voided and the amount of the check subtracted from memory and the report totals. A void operation can be selected either before or after selecting the proper account key.

**NOTE:** If the HE-1500 has been programmed to not allow voiding, the void key will be inoperative.

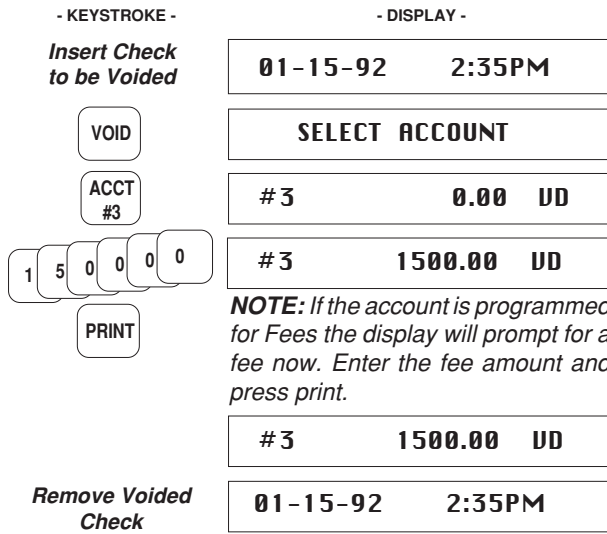

**EXCEEDING PREPROGRAMMED LIMITS:**

If the amount entered exceeds the account limit an error message ("LIMIT EXCEEDED") is displayed for three seconds, and then returns to home menu.

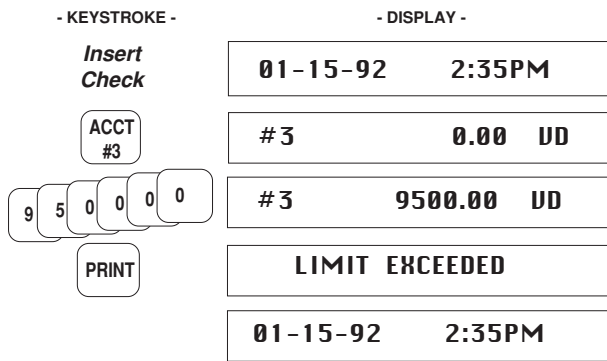

**MEMORY LOW WARNING FUNCTION:**

When the internal memory is nearly full, the following prompt will be displayed:

MEMORY LOW-CLR TOTALS

At 490 checks in memory, an audible tone sounds for three seconds, and the above prompt is displayed. It will continue to be displayed until 500 checks are issued. Then the following prompt is displayed.

MEMORY FULL-CLR TOTALS

When memory is full, all operational keys are disabled except "F" key if password option is used.

If operator passwords are active, depressing the "F" key will allow each operator to print their own report. "MEMORY FULL - CLEAR TOTALS" continues to be displayed until the executive or manager clears the totals.

**OPERATOR REPORTS:**

The "F" key is used to print operator reports, and is only active when the HE-1500 has been programmed for passwords.

Use 8-1/2" x 11" or A-4 paper for printing reports.

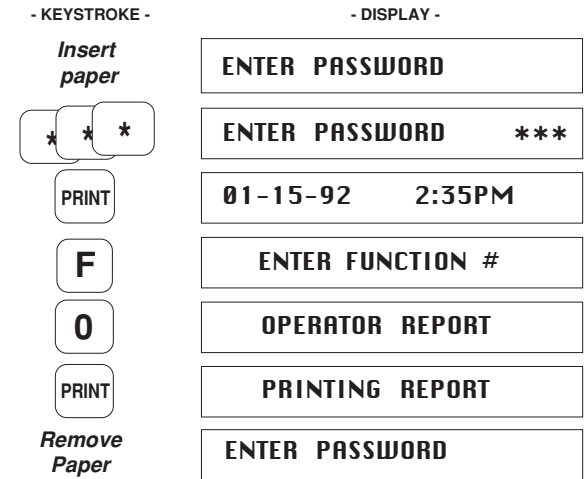

**SUMMARY and DAILY REPORTS, CLEARING TOTALS (MEMORY):**

Summary and Daily Reports are only for Executive or Manager use. A Level 2 password is necessary.

For example purposes we selected #2 to print a Daily Report. A Summary Report would be printed by selecting #1.

Totals can only be cleared after printing either a Daily report or a Summary report. Therefore, it is recommended that both a Summary and Daily report be printed before clearing totals.

Use 8-1/2" x 11" or A-4 paper for printing reports.

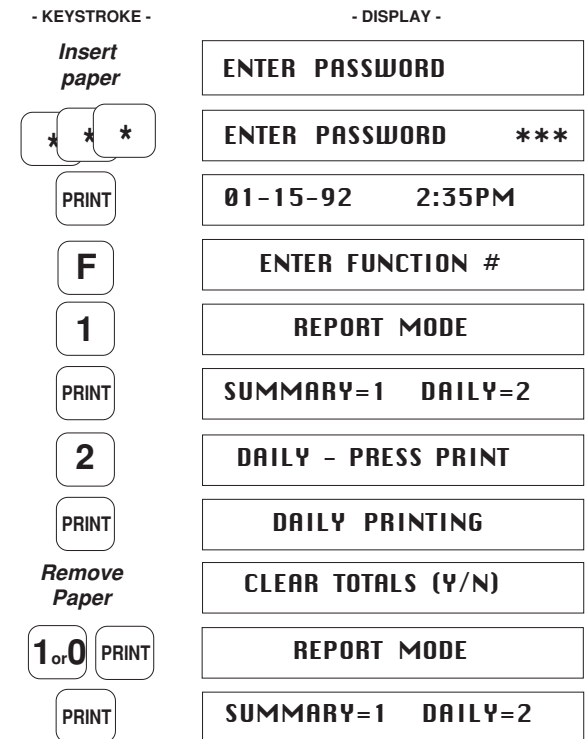

**NOTE:** Use the same key sequence to print a Summary Report