

---

# HEDMAN®

---

The HEDMAN Company • 189 Gordon St. • Elk Grove Village, IL 60007 • 800-872-2788

---

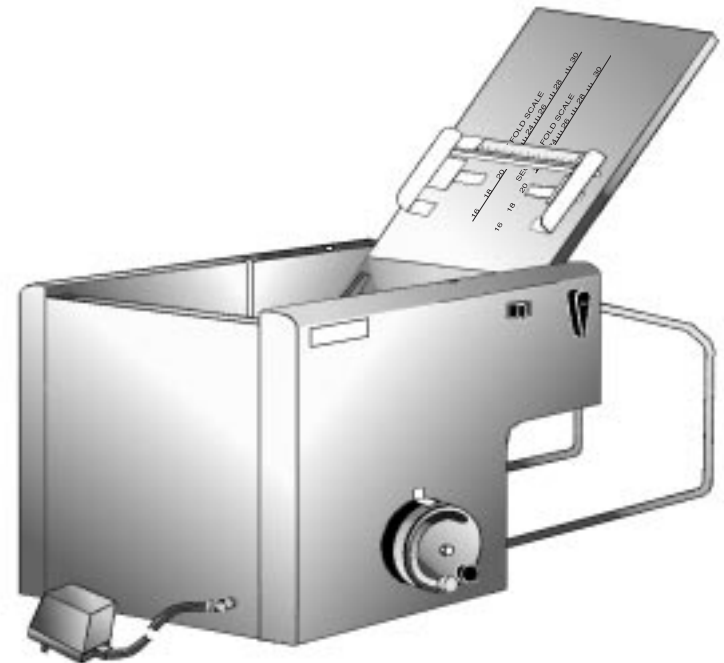

## HF200 FOLDER

### OPERATING & SERVICE MANUAL

THE **HEDMAN** COMPANY  
189 Gordon St.  
Elk Grove Village, IL 60007  
800-872-2788

Printed in U.S.A.  
Form No.198496HF

Form No.198496HF

---

## TABLE OF CONTENTS

---

Page	
4	SPECIFICATIONS
5	COMPONENTS & CONTROLS
6	AUTOMATIC FOLDING
7	MANUAL FOLDING
8	CUSTOM "C" FOLD
9	CUSTOM "Z" FOLD
10	CUSTOM "HALF" FOLD
11-13	MAINTENANCE
11	Removing Cartridge
12	Cleaning Feed Roller
13	Adjusting Separator
14-15	SERVICE
14	Replacing Separator
15	Replacing Feed Roller
16-21	PARTS DRAWINGS & PARTS LISTS
16-17	Drive Assemblies
18-19	Covers & Knobs
20	Fold Pockets
21	Feed Tray
22	TROUBLESHOOTING

### NOTICE

**Proprietary Information** - this material is not to be reproduced by any means or disclosed in any way without prior written approval by THE HEDMAN COMPANY.

**Disclaimer** - this material is subject to change without notice and should not be construed as a commitment by THE HEDMAN COMPANY. Neither express nor implied warranty is made regarding the procedures herein, their merchantability, or fitness for any specific application.

These procedures are provided solely on an "as-is" basis, and the customer agrees to assume any costs arising from use or misuse of the material, including all correction and damages consequential or incidental.

THE **HEDMAN** COMPANY - ALL RIGHTS RESERVED.

© 1997 The Hedman Company

## TROUBLESHOOTING

### 1. FOLD QUALITY

- A. Documents skew - crooked folds
1. As folder runs, adjust PAPER GUIDES slightly to correct the skew.
  2. Re-position paper in HOPPER. Hold HOPPER LEVER open and load paper squarely and centered. Slowly release HOPPER LEVER.
  3. Too much paper in folder. Stop folding and remove some paper. Maximum paper stack is 5/8" (16 mm).
  4. Remove and clean CARTRIDGE.

**WARNING:** Turn POWER SWITCH off and unplug POWER CORD before removing CARTRIDGE.

5. Clean FEED ROLLER.
- B. Fold dimensions are incorrect
1. Refer to pages 8 - 10, Custom Fold Section to fine tune fold dimensions.
  2. Remove CARTRIDGE.
- WARNING:** Turn POWER SWITCH off and unplug POWER CORD before removing CARTRIDGE.
- NOTE:** Use compressed air to blow obstructions out of FOLD POCKETS.

### 2. CLEARING PAPER JAMS

- A. Remove CARTRIDGE and clean (refer to instructions on page 11).
- B. Clean FOLD POCKETS using compressed air.

### 3. DOUBLE FEEDING

- A. Clean FEED ROLLER using alcohol.
- B. Adjust SEPARATOR (refer to instructions on page 13).
- C. Replace FEED ROLLER and SEPARATOR (refer to instructions on page 14).

### 4. NOT FEEDING - IRREGULAR FEED

- A. Change paper if possible. Some types of paper do not feed well.
- B. Clean FEED ROLLER using alcohol.
- C. Replace SEPARATOR and check FEED ROLLER (refer to instructions on page 14).
- D. MOTORS run, FEED ROLLER does not drive, but rotates freely.
1. Replace "O" RING, page 17, #19.

## DECLARATION OF CONFORMITY

(Manufacturer's Declaration according to EC Machinery Directive 89/392/EEC, Annex II A)

**Applicant:** The Hedman Company  
189 Gordon St.  
Elk Grove Village, IL 60007

**Manufacturer:** AUTOMECHA Mfg.  
Route 12  
Oxford, NY 13815

The manufacturer declares that the following described machine complies with the appropriate basic safety and health requirements of the EC Machinery Directive 89/392/EEC, based on its design and type. In case of alteration of the machine, not agreed to by the manufacturer, this declaration will lose its validity.

**Equipment Type:** Paper Folding Machine

**Model Designation:** HF200-IN, HF200-UK.

**Description:** Rated Voltage - 15 VDC (Output of stand-alone power supply)  
Rated Input Power - 1.4A

**Applicable EC Directives:** EC Machinery Directive (89/392/EEC)  
EC Low Voltage Directive (72/23/EEC)  
EC Electromagnetic Compatibility (89/336/EEC)

**Applicable Standards:** EN 292, EN294, EN 60950, EN 55014  
(C.I.S.P.R. 14). EN 50082-1. IEC 801

**Notified Body:** TUV Rhineland  
Sicherheit und Umweltschultz GmbH  
Am Grauen Stein, D-51105 Koln

**Date/Authorized Signature:**

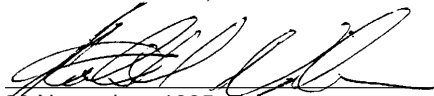
  
20 November, 1995

**Title of Signatory:** Agent

198502HF

## SPECIFICATIONS

<b>POWER:</b>	15V, D.C.(14.8)/1.4 amp/external; wall mountable; power pack with internal circuit breaker UL, CSA & FCC approved 120/220/240 V.A.C., 50/60 HZ International approvals TUV, GS, CE
<b>WEIGHT:</b>	20 lbs. (9.0 kg) / 26 lbs. shipping (11.8 kg)
<b>SPEED:</b>	up to 140 sheets per minute
<b>PAPER SIZE:</b>	minimum: 6" (15.2 cm) length x 5.75" (14.6 cm) width  maximum: 14" (35.6 cm) length x 8.5" (21.6 cm) width
<b>PAPER WEIGHT:</b>	16 to 24 lb. bond/up to 60 lb. offset (50 to 180 GSM)
<b>HOPPER CAPACITY:</b>	up to 150 sheets
<b>MANUAL FEED CAPACITY:</b>	3 sheets stapled or loose
<b>FOOTPRINT:</b>	12" (30.4 cm) long x 13" (33 cm) wide x 8.75" (22.2 cm) high

## FEED TRAY

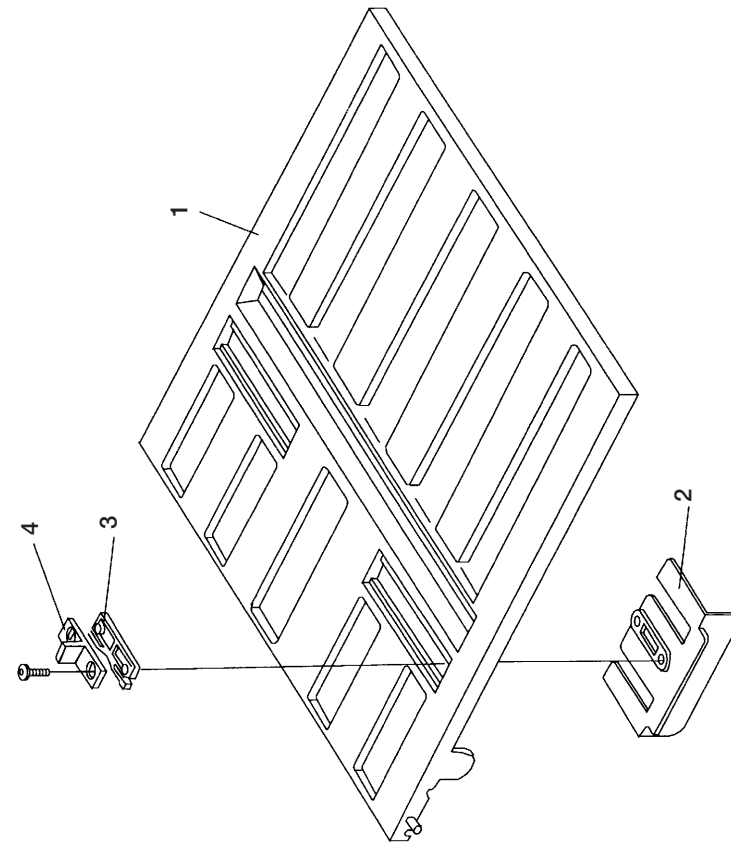

ITEM #	PART #	DESCRIPTION
1	6F1582	COVER, TOP SCREENED
1	6F 1582IN	COVER, TOP SCREENED (FOR A-4 PAPER)
2	3F1544	PAPER GUIDE
3	3F1522	GUIDE SPRING
4	3F1521	GUIDE RETAINER

## FOLD POCKETS

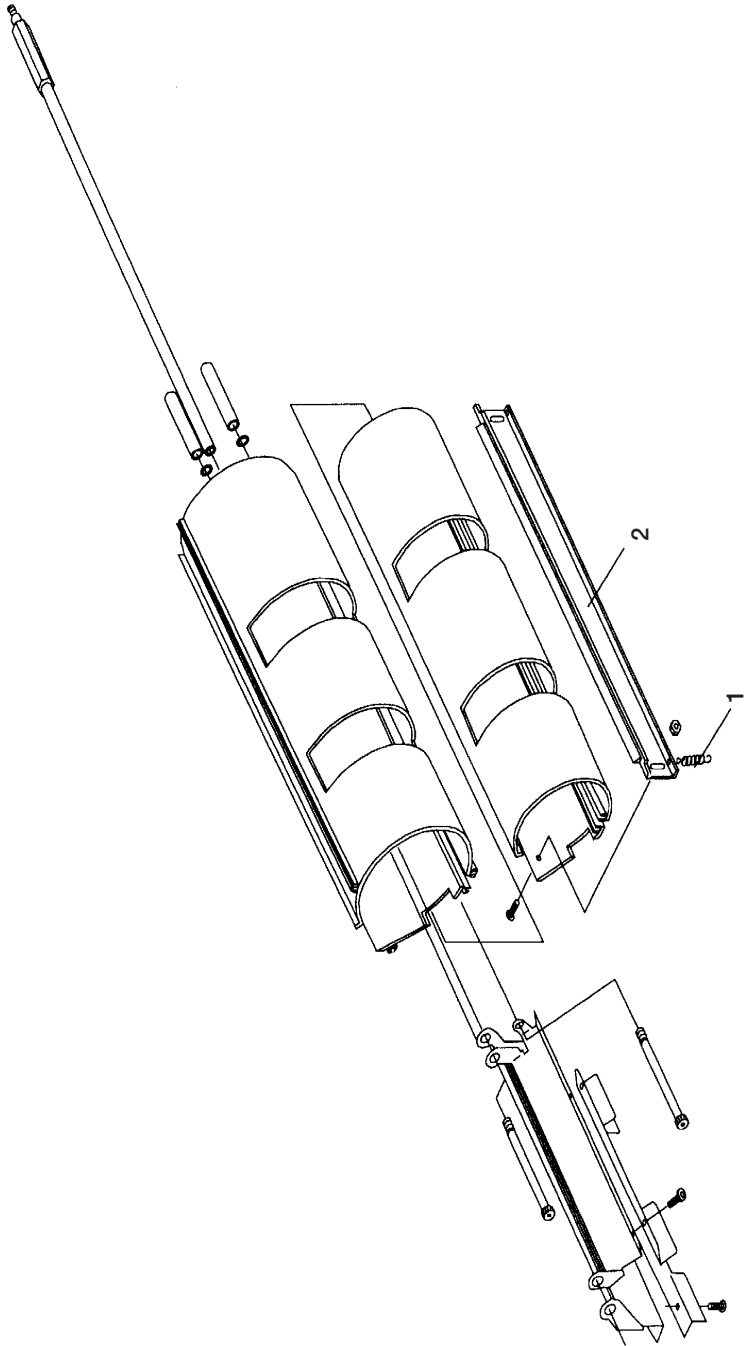

DESCRIPTION  
DEFLECTOR SPRING  
DEFLECTOR

PART #  
3F1533  
3F1506

ITEM #  
1  
2

## COMPONENTS & CONTROLS

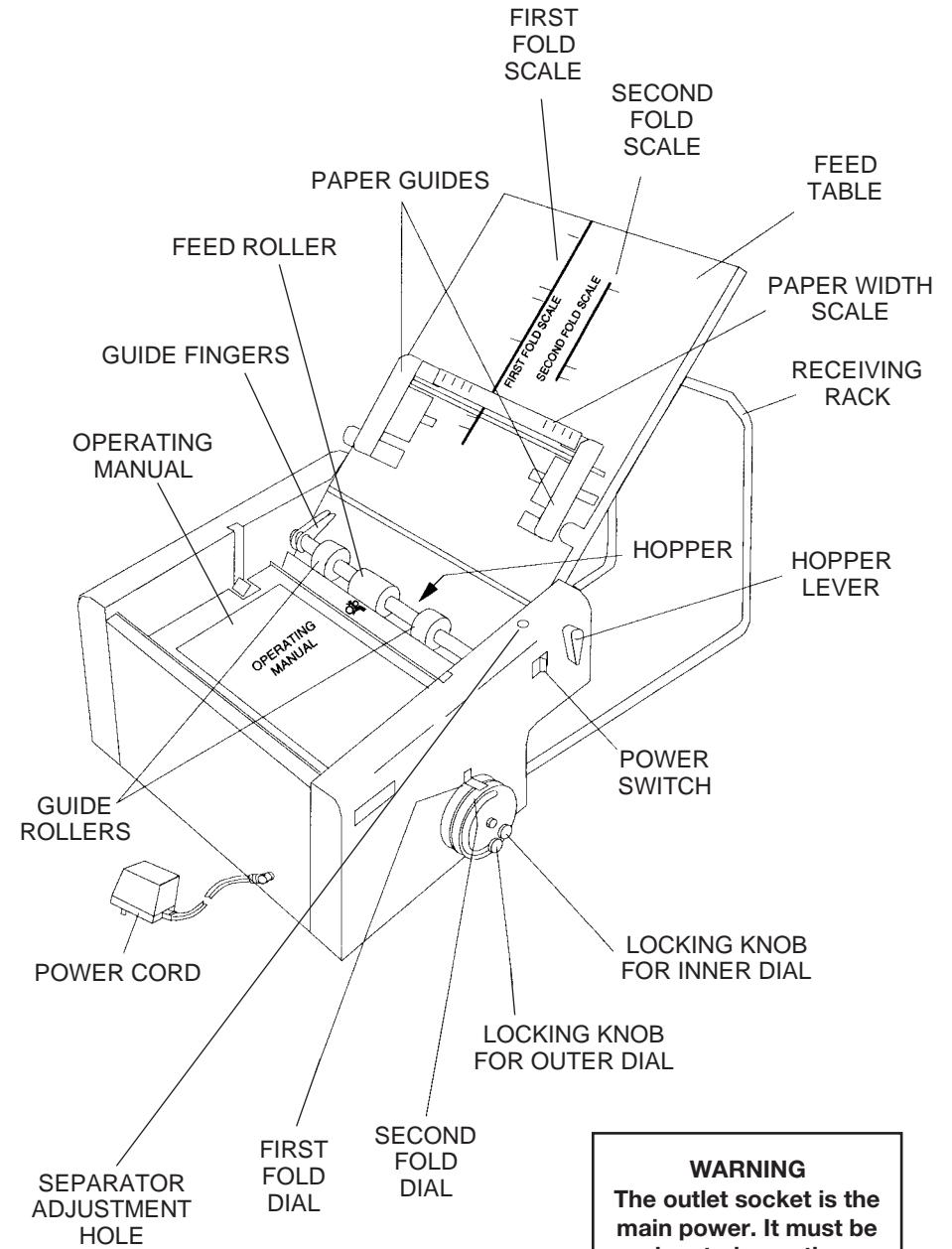

**WARNING**  
The outlet socket is the main power. It must be located near the equipment and easily accessible.

## AUTOMATIC FOLDING

(Stack of sheets up to 5/8" (16 mm) high)

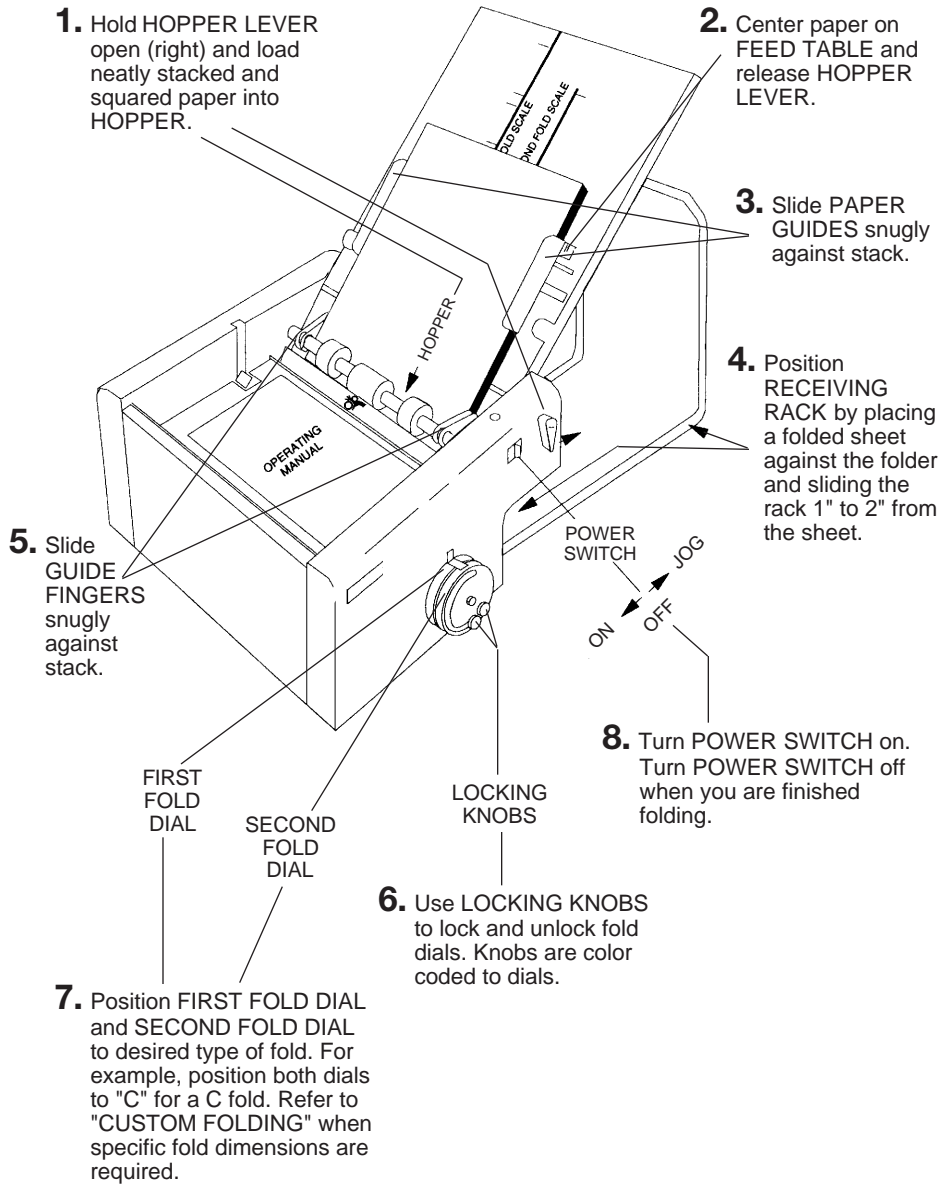

## COVERS & KNOBS

ITEM #	PART #	DESCRIPTION
1	6F1563	DIAL, BOTTOM SCREENED BLK
1	6F1563IN	DIAL, BOTTOM SCREENED BLK (FOR A-4 PAPER)
2	6F1564	DIAL, TOP SCREENED GRAY
2	6F1564IN	DIAL, TOP SCREENED GRAY (FOR A-4 PAPER)
3	3F1640-02	KNOB, DIAL GRAY
4	3F1640-01	KNOB, DIAL BLACK
5	3F1630	NUT, ACORN 1/4-28, BLK ZI
6	3F1618	INDICATOR, DIAL
7	6F1549-02	COVER ASSEMBLY
8	3F1609	LEVER
9	7F1596	SEPARATOR SHAFT ASSEMBLY
10	3P1911	RUBBER FOOT
11	3F1553	POWER SUPPLY (120V)
11	3F1643	EUROPE POWER SUPPLY (220V)
11	3F1642	UNITED KINGDOM POWER SUPPLY (220V)
12	3F1549-01	COVER, NON-OPERATOR SIDE
13	7F1656	ON/OFF/JOG SWITCH AND HARNESS
14	7F1571	POWER JACK ASSEMBLY - NOT SHOWN
15	3F1657	LABEL, SWITCH - NOT SHOWN
16	3F1619	SHIPPING CARTON, MACHINE - NOT SHOWN
17	3F1565	SPACER, LONG
18	3F1607	CORK PATCH
19	3F1592	SPRING WINDER (Not shown - only on machines with Serial # 300D1471 and lower)
20	3F1591	SPRING (Not shown - only on machines with Serial # 300D1471 and lower)
21	3F1653	SPRING, FEED DOOR (Only on machines with Serial # 300D1471 and higher)
22	3F1541	BASE
23	3F1599	PAPER DEFLECTOR
24	3F1586	FEED DOOR
25	3F1539	FRONT BAFFLE
26	6F1545	LARGE END
27	3F1546	INNER COVER
28	3F1585	PAPER END STOP
29	3F1506	PAPER DEFLECTOR EXTRUSION

## COVERS & KNOBS

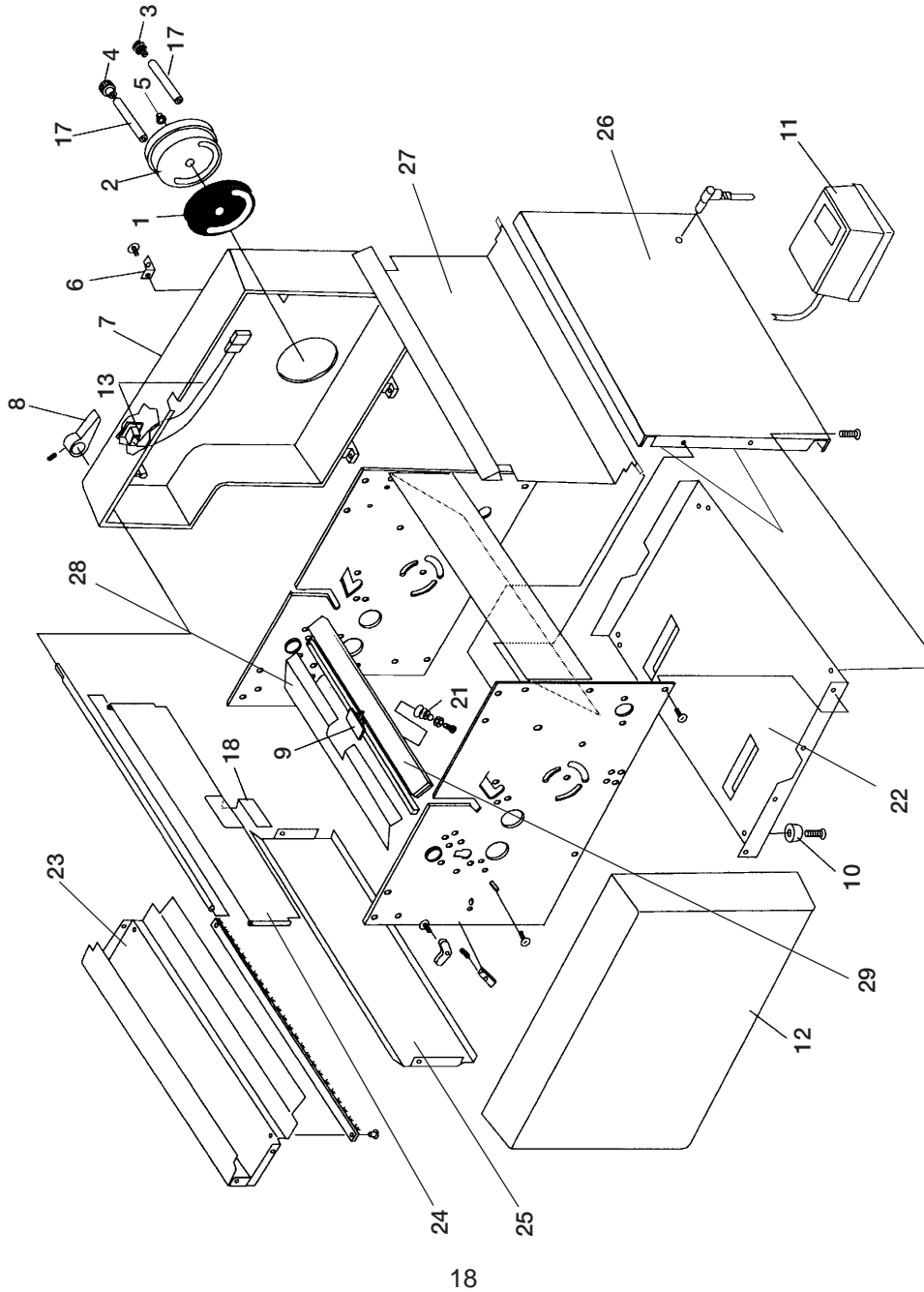

## MANUAL FOLDING

(1 to 3 sheets stapled or loose)

1. Close FEED TABLE onto top of folder.

2. Slide PAPER GUIDES as far apart as possible.

3. Verify that FOLD DIALS are set to desired dimensions. (Refer to #6 & 7 on page 6.)

4. Insert sheet(s) squarely into SLOT and let them rest on your finger as shown. **Do not hold sheet(s).**

5. Turn POWER SWITCH to JOG until paper is folded.

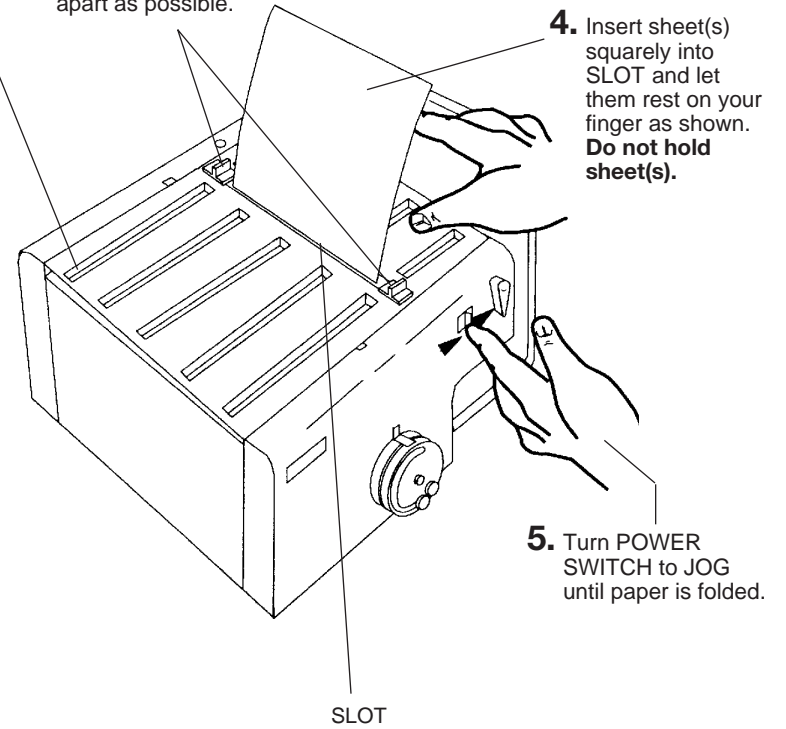

## CUSTOM "C" FOLD

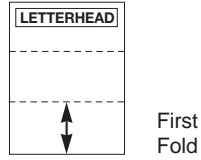
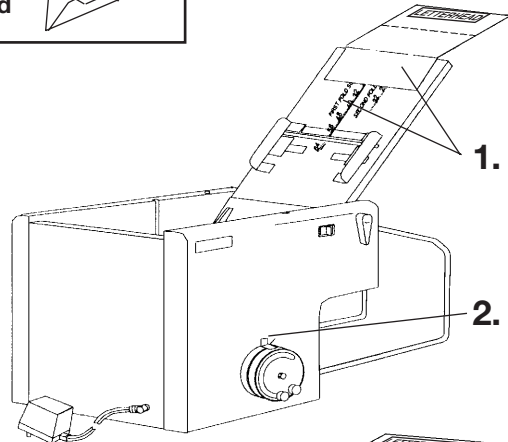
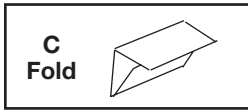

**1.** Hand fold a sheet of paper to desired size. Unfold and measure **bottom panel** on **FIRST FOLD SCALE**.

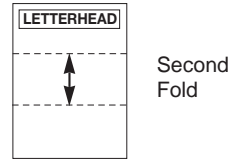
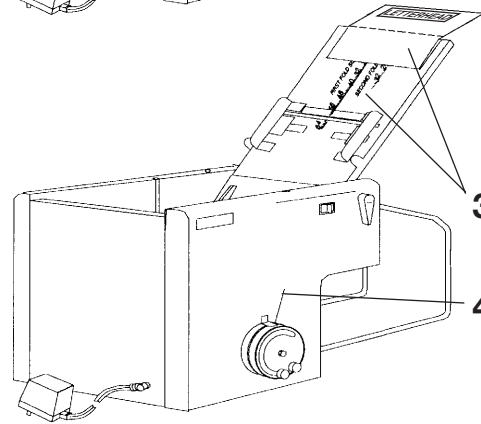

**2.** Set **FIRST FOLD DIAL** to measured distance and lock in place.

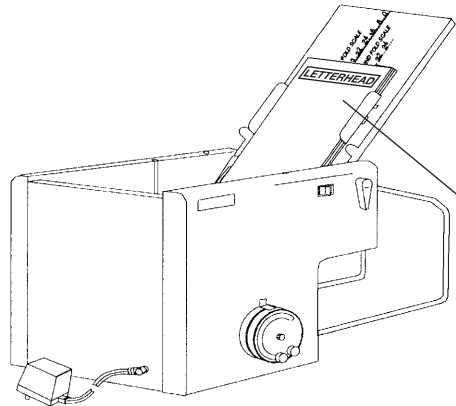

**3.** Measure **center panel** on **SECOND FOLD SCALE**.

**4.** Set **SECOND FOLD DIAL** to measured distance and lock in place.

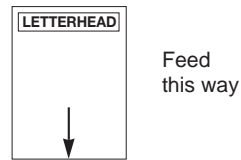

**5.** Load paper with letterhead **facing up on top of stack**. Run 2-3 sheets to make sure fold is correct. Fine tuning may be necessary.

## DRIVE ASSEMBLIES

ITEM #	PART #	DESCRIPTION
1	3F1559	GEAR (24T 20PA 24P)
2	7F1525	FEED ROLL ASSEMBLY
3	3F1536	PULLEY, FEED ROLL
4	3F1601	GUIDE, FRONT
5	3F1581	SPRING, CLUTCH
6	3F1602	BUSHING, SPLIT
7	3F1608	ROLLER, GUIDE
8	3F1525	ROLLER, FEED
9	7F1519	GEAR ASSEMBLY
10	3P1916	MICRO SWITCH
11	3F1556	MOTOR
12	3F1511-02	PRESSURE LEVER (OPERATOR SIDE)
13	3F1511-01	PRESSURE LEVER (NON-OPERATOR SIDE)
14	3F1514-01	SPRING, PRESSURE LEVER (NON-OPERATOR SIDE)
15	3F1514-02	SPRING, PRESSURE LEVER (OPERATOR SIDE)
16	7F1551	CARTRIDGE ASSEMBLY
17	3F1594	HOLDER, SQUARE SHAFT
18	3F1510	BEARING RETAINER SHORT
19	3F1637	"O" RING
20	3F1603	PULLEY, SMALL FEED
21	3F1557	BELT, 1/5 PITCH (134XL037)
22	3F1555	PULLEY, DRIVE 26T
23	7F1526	2 STEP PULLEY ASSEMBLY
24	3F1558	BELT, 1/5 PITCH (148XL037)
25	3F1554	PULLEY, MOTOR 10T
26	3F1552	BEARING
27	3F1543	RECEIVING RACK
28	05-0795-00	CAM SWITCH
29	02-1598-02	RUBBER "O" RINGS

## DRIVE ASSEMBLIES

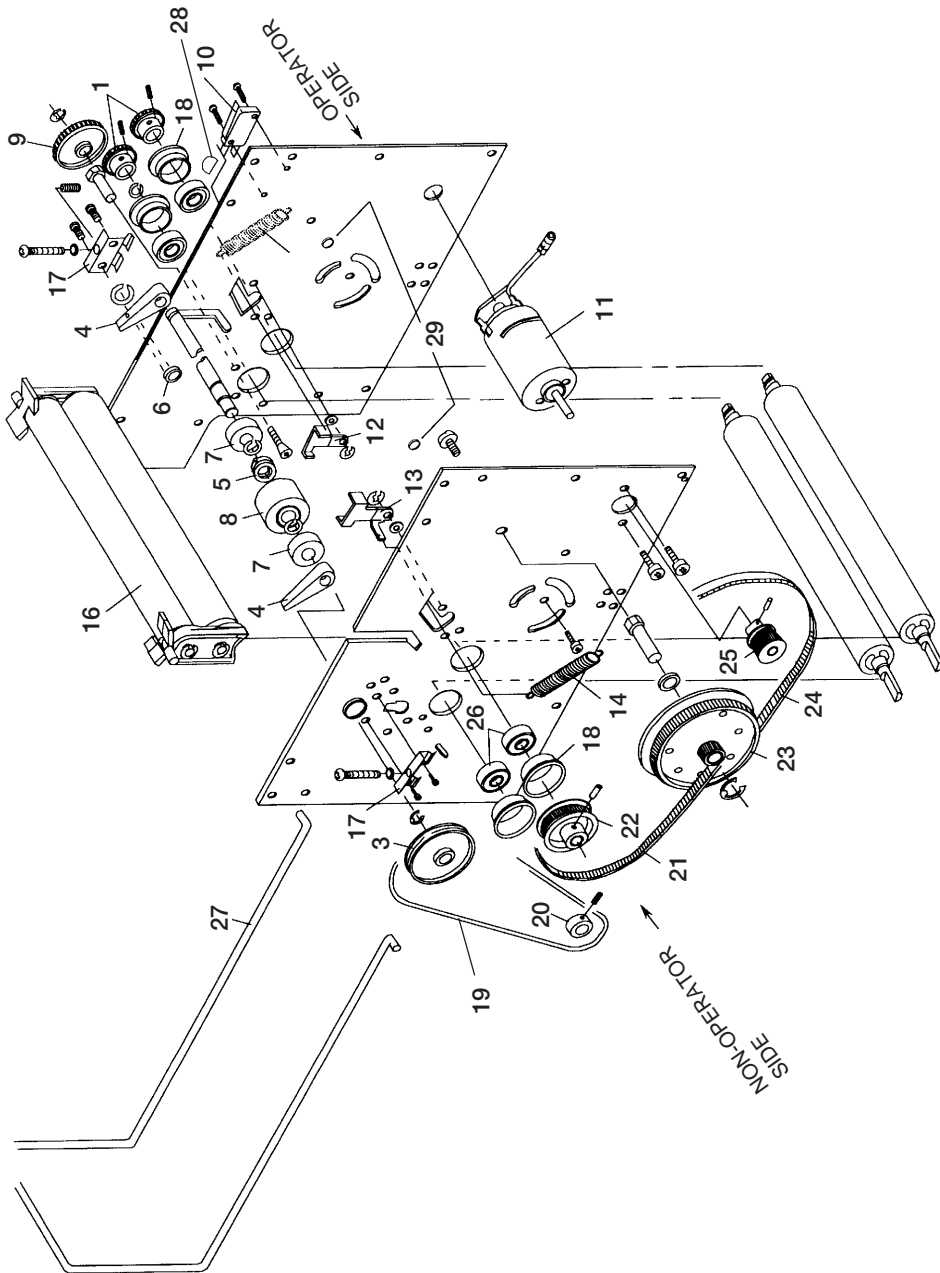

## CUSTOM "Z" FOLD

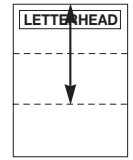
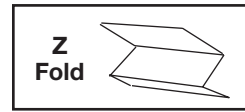

First Fold

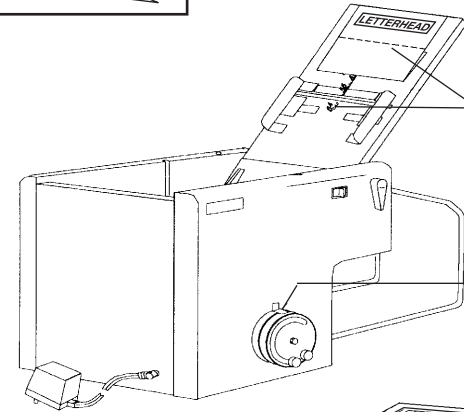

1. Hand fold a sheet of paper to desired size. Unfold and measure **top two panels** on **FIRST FOLD SCALE**.

2. Set **FIRST FOLD DIAL** to measured distance and lock in place.

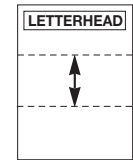

Second Fold

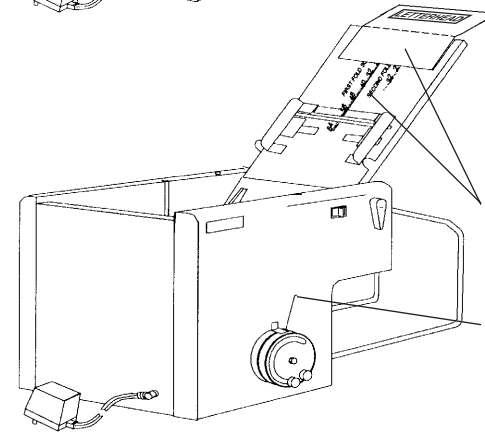

3. Measure **center panel** on **SECOND FOLD SCALE**.

4. Set **SECOND FOLD DIAL** to measured distance and lock in place.

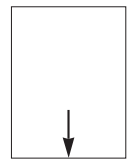

Feed this way

Other side

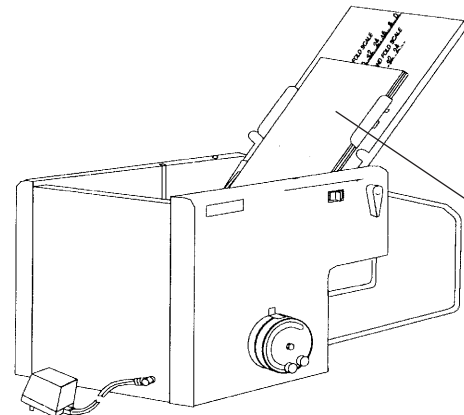

5. Load paper with letterhead **facing down on bottom of stack**. Run 2-3 sheets to make sure fold is correct. Fine tuning may be necessary.

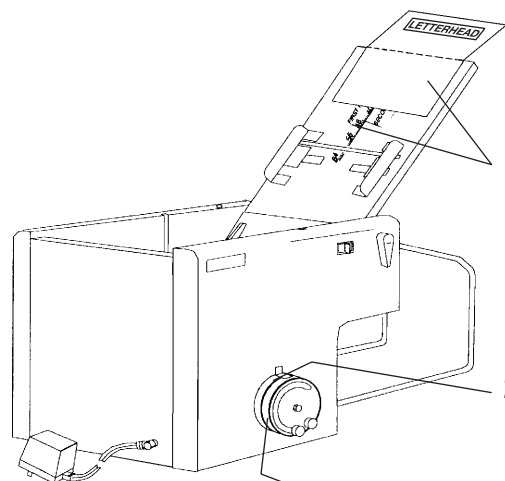
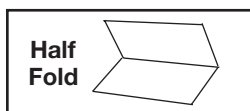

1. Hand fold a sheet of paper to desired size. Unfold and measure **bottom panel** on **FIRST FOLD SCALE**.
2. Set **FIRST FOLD DIAL** to measured distance and lock in place.
3. Set **SECOND FOLD DIAL** ***firmly counterclockwise*** and lock it in place.

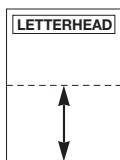

First Fold

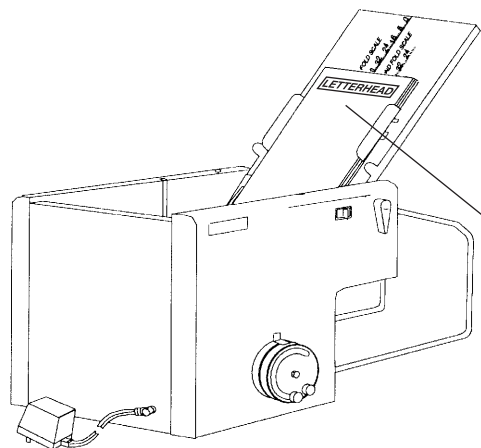

4. Load paper with letterhead ***facing up on top of stack***. Run 2-3 sheets to make sure fold is correct. Fine tuning may be necessary.

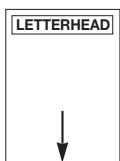

Feed this way

## Replacing FEED ROLLER

If the FEED ROLLER is visibly worn or is chunking apart, it must be replaced. When changing the SEPARATOR, replace the FEED ROLLER as well.

### To change the FEED ROLLER:

1. Turn POWER SWITCH off and unplug POWER CORD.
2. Remove SIDE COVERS.
3. Remove DRIVE BELT and PULLEY.
4. Remove the "E" RINGS on the inside of frames next to the OILITE BUSHINGS. **NOTE: OILITE BUSHINGS are pressed in and removal is not necessary.**
5. Loosen GUIDE ROLLERS and slide the shaft 3 to 4 inches to the operator side so GUIDE FINGER, BUSHING and GUIDE ROLLER can be removed.
6. Remove the "E" RING located next to the FEED ROLLER. Slide the FEED ROLLER off as well as the CLUTCH SPRING. Inspect inside of CLUTCH SPRING for wear. If a "flat" wear area has appeared instead of normal rounded coils, replace the CLUTCH SPRING (part# 3F1581).
7. Clean the shaft and lightly lubricate with a light machine oil, the area on the shaft where the CLUTCH and FEED ROLLER are mounted. Reassemble the FEED SHAFT.
8. The FEED ROLLER should spin easily in one direction and "lock-up" when spun in the opposite direction. **NOTE: If the roller does not "lock-up", there is too much lubrication between CLUTCH SPRING and FEED SHAFT.**
9. Re-assemble shaft into frame.
10. Lightly oil the OILITE BEARINGS for the FEED SHAFT and make sure the FEED SHAFT spins freely in the side frames.

## Replacing SEPARATOR

The SEPARATOR (located below the FEED ROLLER) is a **very important** part of the automatic feeding system. Keeping the SEPARATOR adjusted as it wears (see Page 12) will insure proper operation. If the adjustment screws run out of travel and can no longer be adjusted, the SEPARATOR HOLDER ASSEMBLY (part # 7F1596) must be replaced. It is also recommended that the FEED ROLLER (part # 3F1525) and CLUTCH SPRING (part # 3F1581) be replaced.

### To change the SEPARATOR:

1. Turn POWER SWITCH off and unplug POWER CORD.
2. Remove both SIDE COVERS. **NOTE:** *The fold dials must be removed.* Observe the alignment of dials and tightness of ACORN NUT for dial tension. Remember to reconnect the POWER SWITCH.
3. Remove the PAPER DEFLECTOR (with static brush attached) at the output end of folder by removing the screws in the side frame.
4. Remove the plastic FEED SHAFT PULLEY on the non-operator side and remove the square SHAFT HOLDER on both sides as well as the SEPARATOR ADJUSTING SCREW and SPRING.
5. Remove the loose SEPARATOR SQUARE SHAFT ASSEMBLY through the output end of the folder. Turn the shaft so the pin on the non-operator side clears the keyhole.
6. Install the new SEPARATOR SHAFT ASSEMBLY the same way old assembly was removed.
7. Assemble the SQUARE SHAFT HOLDER on non-operator side first. **NOTE:** *Make sure the SEPARATOR PATCH is positioned to fit through the hole under the FEED ROLLER. The SQUARE SHAFT should slide through the slots with little or no interference.*
8. Re-assemble SEPARATOR ADJUSTMENT ASSEMBLY and re-adjust the SEPARATOR using instructions on Page 13.

## Removing CARTRIDGE

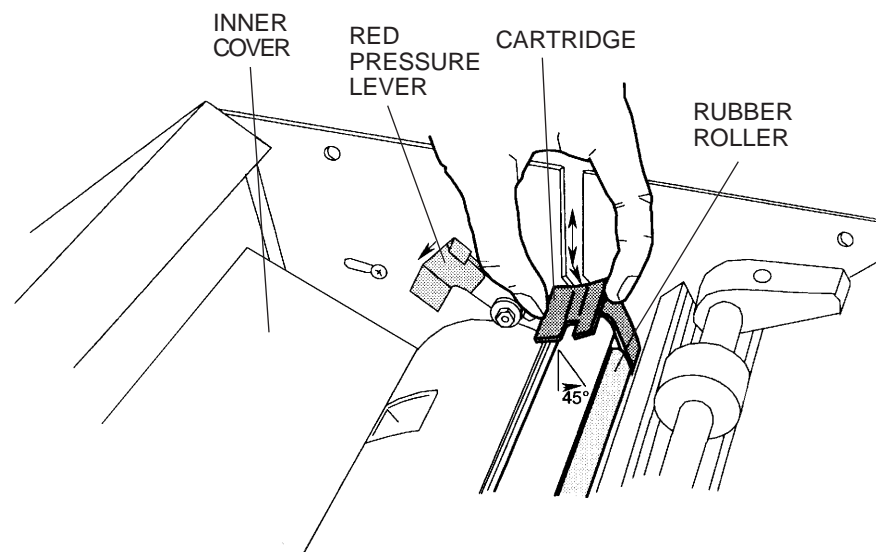

**WARNING:** Turn POWER SWITCH off and unplug POWER CORD before removing CARTRIDGE.

### To Remove CARTRIDGE:

1. Open TOP and INNER COVERS.
2. Pull back RED PRESSURE LEVERS.
3. Remove CARTRIDGE by sliding it up and out of the folder in the slot. When installing CARTRIDGE, the RUBBER ROLLER must be held at a 45° angle toward the feed end of folder (refer to illustration above).
4. Once in place, push the CARTRIDGE down to make sure it is in place and leveled.
5. Close RED PRESSURE LEVERS.
6. Close TOP and INNER COVERS. Important: INNER COVER must be closed or folder will not run.

**NOTE:** *If CARTRIDGE has wear marks, cuts, etc., it must be replaced. (Part # 7F1551).*

## Cleaning FEED ROLLER

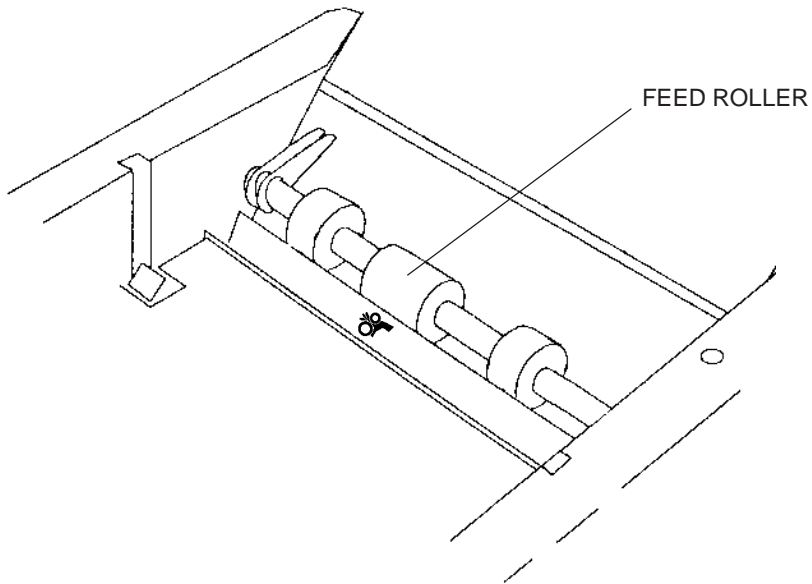

### To clean FEED ROLLER:

1. Turn POWER SWITCH off.
2. Using a cloth and alcohol, clean entire FEED ROLLER.
3. Allow FEED ROLLER to dry completely before folding.

## Adjusting SEPARATOR

The SEPARATOR must be set to feed one sheet of paper at a time.

**WARNING:** Turn POWER SWITCH off and unplug POWER CORD before making adjustment.

### To adjust SEPARATOR:

1. Clean FEED ROLLER before adjusting SEPARATOR. (Refer to page 12.)
2. Fold a strip of standard (20# bond) paper in half. Hold HOPPER door open. Turning the FEED ROLLER by hand, feed the sheet under the roller.
3. Hold the FEED ROLLER so it cannot turn. Pull the strip out. It should pull out with some difficulty.

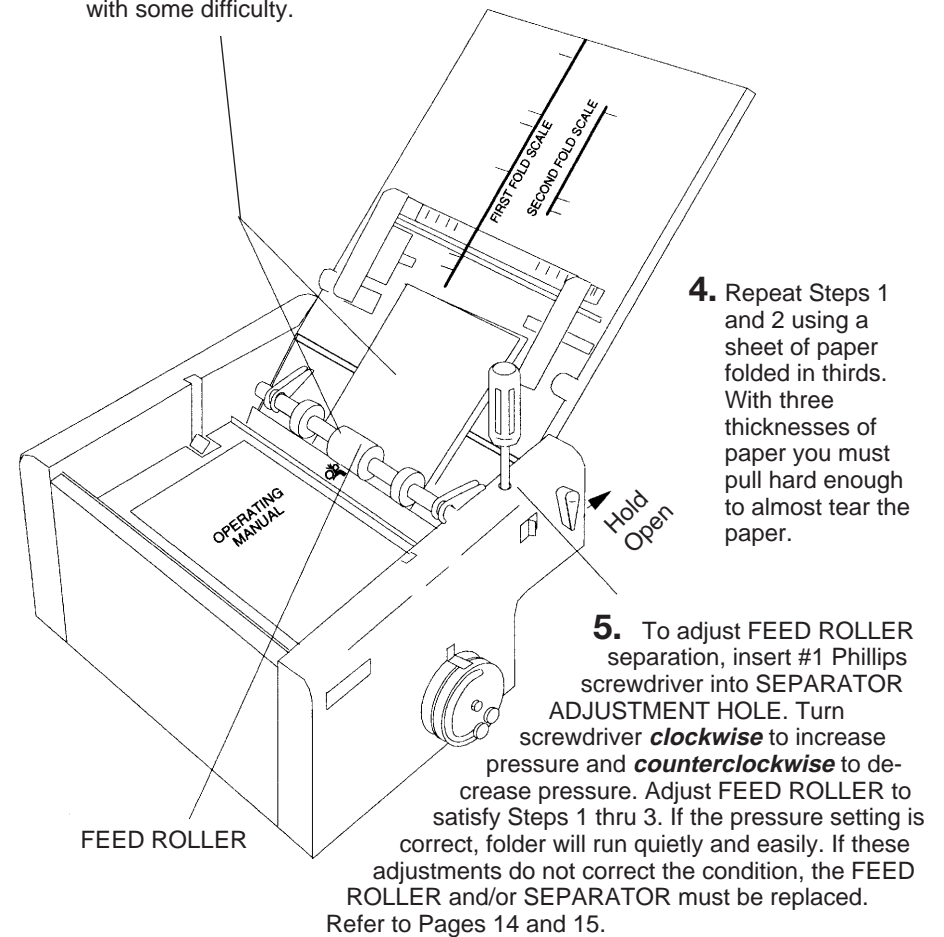

4. Repeat Steps 1 and 2 using a sheet of paper folded in thirds. With three thicknesses of paper you must pull hard enough to almost tear the paper.

5. To adjust FEED ROLLER separation, insert #1 Phillips screwdriver into SEPARATOR ADJUSTMENT HOLE. Turn screwdriver **clockwise** to increase pressure and **counterclockwise** to decrease pressure. Adjust FEED ROLLER to satisfy Steps 1 thru 3. If the pressure setting is correct, folder will run quietly and easily. If these adjustments do not correct the condition, the FEED ROLLER and/or SEPARATOR must be replaced. Refer to Pages 14 and 15.